

THESE DRAWINGS ARE THE PROPERTY OF QUALTEK ELECTRONICS AND NOT TO BE REPRODUCED FOR OR COMMUNICATED TO A THIRD PARTY WITHOUT THE EXPRESS WRITTEN PERMISSION OF AN OFFICER OF QUALTEK ELECTRONICS.

REVISION			
REV.	DESCRIPTION	DATE	APPROVED
B	RoHS Compliancy	06-01-06	DP
C	Updated Specifications	01-10-08	DP

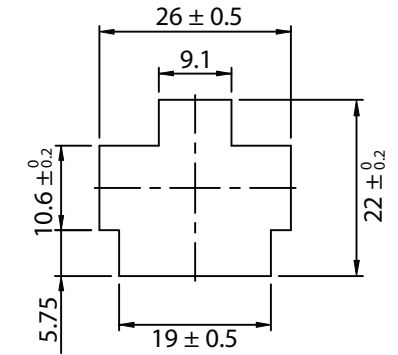
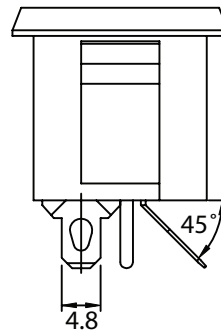
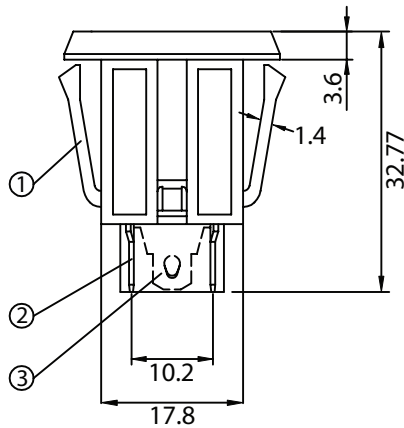
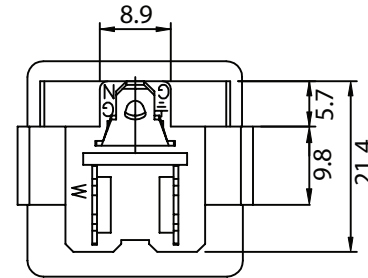
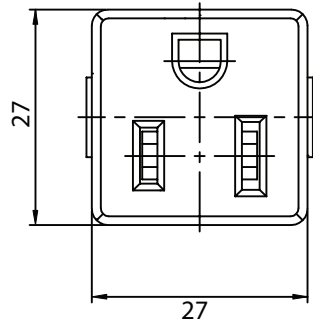

PANEL THICKNESS RANGE: 0.8mm~2.0mm

CONTROLLED

NOTES:

RATING: 15A 125V AC
 MATERIAL: UL94-V0
 APPROVALS: UL, cUL, CSA
 PANEL THICKNESS: 0.8mm~2.0mm
 RoHS COMPLIANT

3	Soldering PIN B 0.6t Tin-Plated	1
2	Soldering PIN A 0.6t Tin-Plated	2
1	Body Insulator NYLON 21SP Color: Black	1

Dim range (mm)	Tolerance +/- (mm)	Qualtek Electronics Corp. PPC DIVISION		
		Part Number:	738W-X2/03	
0-1	0.15	Description: NEMA 5-15 RECEPTACLE		
1-6	0.20		UNIT: mm	REV.C
6-18	0.30			
18-50	0.50			
50-120	0.70	Drawn / Date	Checked / Date	Approved / Date
120-250	0.90	B.ZHANG 01-29-04	01-29-04	JJH / 01-29-04
250-500	1.20			